

DATI TECNICI TECHNICAL DATA

15	3840*	1620*	995	770	550			
kg	1.0	2.31	3.86	4.98	6.44			
m.								
25	3630*	1570*	990	710	550	420		
kg	1.0	2.27	3.67	5.03	6.39	7.85		
m.								
35	3500*	1500*	930	650	500	410	320	
kg	1.0	2.27	3.77	5.13	6.49	7.85	9.31	
m.								
45	3370*	1450*	870	600	450	360	300	240
kg	1.0	2.27	3.87	5.23	6.59	7.95	9.31	10.77
m.								

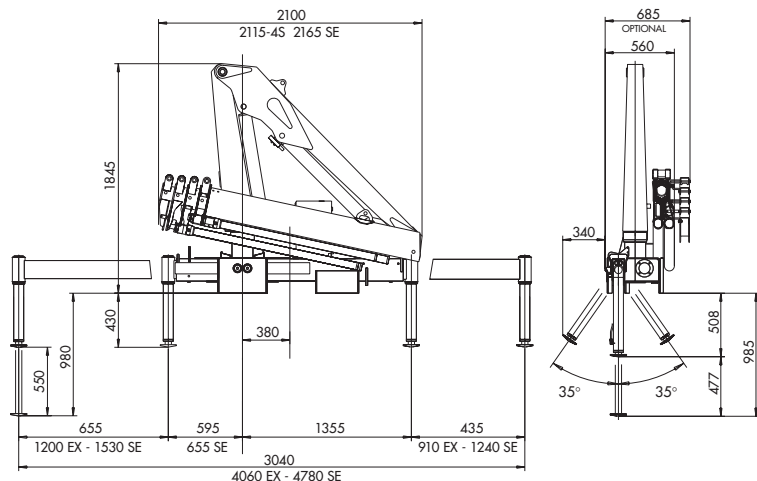

(*) Portata teorica Theoretical lifting capacity

MOMENTO DI SOLLEVAMENTO MAX.
LIFTING MOMENT
MOMENT D'ELEVATION MAX.
MAX. AUFHEBEMOMENT
MOMENTOS DE ELEVACION
MOMENTO DE ELEVACAO MAX.
(t.m.)

3,8

PENDENZA MAX. DI LAVORO
MAX WORKING HEEL
DEVERS MAXI DE TRAVAIL
MAX. ARBEITSNEIGUNG
INCLINACION MAX. DE TRABAJO
PENDENCIA MAX. DE TRABALHO
(°)

4°

CAPACITÀ SERBATOIO OLIO
OIL TANK CAPACITY
CONTENANCE RESERVOIR HUILE
ÖLBEHÄLTERINHALT
CAPACIDAD DEL DEPÓSITO ACEITE
CAPACIDADE DO DEPOSITO DE OLEO
(l.)

35

SBRACCIO MAX. VERTICALE
MAX VERTICAL REACH
LONGEUR DU BRAS VERTICALE
MAX VERTIKAL REICHWEITE
ALCANCE MAX. VERTICAL
ALCANCE MAX. VERTICAL
(m.)

15 25 35 45

hyd. 7,82 9,26 10,6 12,1
man. 9,62 10,7 12,1 13,5

PRESSIONE D'ESERCIZIO
WORKING PRESSURE
PRESSION DE SERVICE
BETRIEBSDRUCK
PRESIÓN DE TRABAJO
PRESSÃO DE TRABALHO
(bar)

base 225

PORTATA AL DISTRIBUTORE
OIL HYDRAULIC DISCHARGE TO THE DISTRIBUTOR BOX
DÉBIT D'HUILE HYDRAULIQUE AU DISTRIBUTEUR
HYDRAULISCHE ÖL TRAGFAHIGKEIT ZUM VERTEILER
CAUDAL AL DISTRIBUIDOR
DESCARGA DE OLEO HIDRAULICO AO DISTRIBUIDOR
(l/min.)

base 16

ANGOLO DI ROTAZIONE
SLEWING ANGLE
ANGLE ROTATION
SCHWENKBEREICH
ANGULO DE ROTACION
ANGULO DE ROTAÇÃO
(°)

380°

PESO GRU SENZA STABILIZZATORI
CRANE WEIGHT WITHOUT STABILIZER
MASSE GRUE SANS STABILISATEURS
KRANGEWICHT OHNE ABSTÜTZUNGEN
PESO DE LA GRUA SIN GATOS
PESO DA GRUA SEM ESTABILIZADORES
(kg.)

15 25 35 45

base 625 675 725 770

VELOCITÀ DI ROTAZIONE
SLEWING SPEED
VITESSE DE ROTATION
DREHGESCHWINDIGKEIT
VELOCIDAD DE ROTACION
VELOCIDADE DE ROTAÇÃO
(180°)

805

15s (1s/2s)
20s (3s/4s)

PESO STABILIZZATORI
WEIGHT OF STABILIZERS
POIDS DES STABILISATEURS
GEWICHT DER STABILISATOREN
PESO GATOS EXTENSIBLES
PESO DOS ESTABILIZADORES
(kg.)

805

base 85

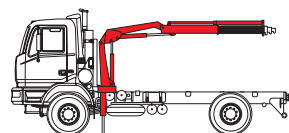

Passo - Wheelbase - Empattement - Passo: 3450 mm. M.T.T. ton 5,0
G.V.W. ton 5,0

Autocarro consigliato
Recommended truck
Camion conseillé
Camion aconsejado
Caminhão aconselhado

ACCESSORI ACCESSORIES ACCESSOIRES ZUBEHOERE ACCESORIOS ACCESORIOS

- Limitatore di momento
- Prolonghe meccaniche
- Stabilizzatori girevoli
- Attivazione elementi supplementari
- Posto di manovra in alto
- Verricello
- Stabilizzatori allargabili idraulicamente
- Stab. extra estendibili
- Load limiting device
- Manual extensions
- Turning stabilizers
- Supplementary element activation
- Top seat
- Winch
- Outriggers with hydraulic extension
- Extra extendible stab.
- Limiteur de moment
- Rallonges mécaniques
- Stabilisateurs pivotants
- Activation éléments supplémentaires
- Siège en haut
- Treuil
- Stabilizateurs élargissables hydrauliquement
- Stab. coulissants extra-extensibles
- Momentbegrenzer
- Mechanische Verlängerungen
- Dreh stabilisatoren
- Extra-Funktionen
- Hochsitz
- Winde
- Hydraulisch ausfahrbare Abstützungen
- Extra Abstützungen
- Limitador de momento
- Prolongaciones mecánicas
- Gatos giratorios
- Activación elementos suplementarios
- Puesto de maniobra arriba
- Cabrestante
- Estabilizadores extraíbles hidráulicamente
- Estab. extra extensives
- Limitador de momento
- Prolongações mecánicas
- Estabilizadores giratórios
- Ativação de elementos suplementares
- Posto de manobra no cimo
- Guincho
- Estabilizador alongado hidráulicamente
- Estab. extra extensives

Dati, descrizioni e illustrazioni sono indicativi e non impegnano Amco Veba. Gru prodotte e/o commercializzate da Amco Veba - Data, descriptions and illustrations are merely indicative and not binding. Cranes manufactured and marketed by Amco Veba - Les données, descriptions et illustrations sont uniquement indicatives et n'engagent pas Amco Veba. Grues produites et/ou vendues par Amco Veba - Angaben, Beschreibungen und Abbildungen sind weisend und verpflichten nicht Amco Veba. Die Kräne werden von Amco Veba hergestellt und/oder vermarktet - Los datos, las descripciones y las ilustraciones son indicativos y no implican compromiso para Amco Veba. Gruas producidas y/o comercializadas por Amco Veba - Os dados as descrições e ilustrações são indicativos e não comprometem Amco Veba. Guindaste produzidos e/ou comercializados pela Amco Veba.



Amco Veba s.r.l.
Via Einstein, 4
42028 Poviglio (RE) Italy
Tel. +39 0522 40.80.11
Fax +39 0522 40.80.80
E-mail: commerciale@amcoveba.it
www.amcoveba.com

COMPANY WITH QUALITY SYSTEM CERTIFIED BY DNV =ISO 9001/2000=



904 RRS 804





- Comandi bilaterali (804)
- Comando a distanza (904RRS)
- Sfili esagonali
- Mart. sfilo indipendenti
- Valvole flangiate
- Serbatoio olio
- Kit di montaggio
- Raccorderia SAE-JIC
- Norma di progettazione: DIN 15018 - EN 12999
- Classe di collaudo a fatica: B3



- Dual controls (804)
- Remote control (904RRS)
- Hexagonal section extensions
- Independent extension cylinders
- Flanged valves
- Oil tank
- Assembly kit
- Fittings SAE-JIC
- Design in accordance with DIN 15018 - EN 12999
- Fatigue test classification: B3



- Commandes bilaterales (804)
- Commande à distance (904RRS)
- Extensions hexagonales
- Vérins d'extension indépendants
- Valves bridée
- Réservoir d'huile
- Kit de montage
- Tujauterie SAE-JIC
- Normes de calcul: DIN 15018 - EN 12999
- Tests de fatigue en classe: B3



- Beidseitige Kransteuerung (804)
- Fernsteuerung (904RRS)
- Sechskantige Auszüge
- Unabhängige Auszugszylinder
- Ventile mit Flansch
- Öltank
- Montagesatz
- Anschlüsse SAE-JIC
- Berechnungsnorm nach DIN 15018 - EN 12999
- Ermüdungstest in Klasse: B3



- Mandos bilaterales (804)
- Mando a distancia (904RRS)
- Brazos telescópicos hexagonales
- Cilindros extensión independientes
- Válvulas pilotadas
- Tanque de aceite
- Kit de ensamblaje
- Conexiones SAE-JIC
- Norma del proyecto: DIN 15018 - EN 12999
- Tipo de ensayo a la fatiga: B3



- Comandos bilaterales (804)
- Comando a distancia (904RRS)
- Extensões sextavadas
- Cilindros de extensão independentes
- Válvulas de segurança
- Tanque de óleo
- Kit de montagem
- Conexões SAE-JIC
- Norma de projeto DIN 15018 - EN 12999
- Tipo de Teste a la fatiga: B3



904 RRS Radiocomando palmare proporzionale

RADIO REMOTE STANDARD

Single hand proportional system

Possibilità di comandare via radio ogni movimento della gru utilizzando una sola mano
Single-handed control of every crane function

Regolazione proporzionale della velocità di ogni singolo movimento
Proportional speed control of any single movement

Comando via radio dei piedi stabilizzatori
Stabilizer control by radio



Selezione del movimento
Function selection

Selettore proporzionale della velocità
Proportional speed control

Dimensione compatte e peso contenuto
Compact dimensions and reduced weight

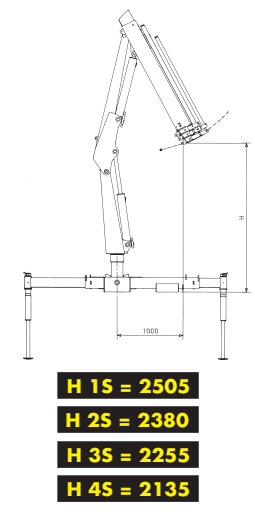
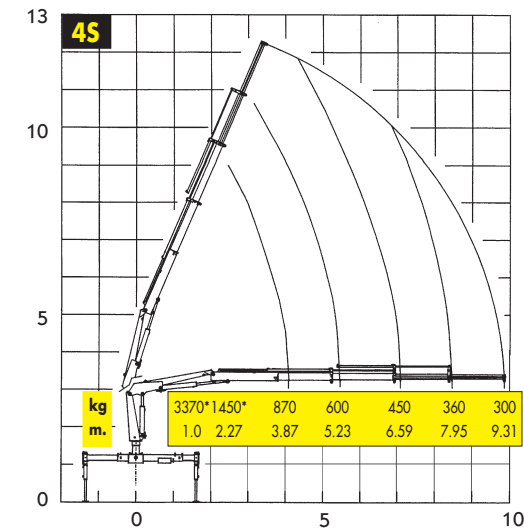
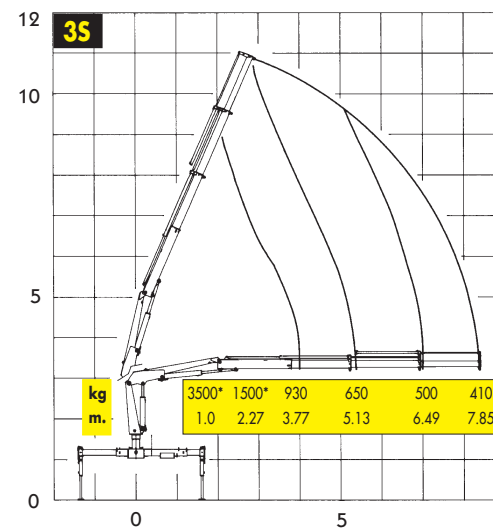
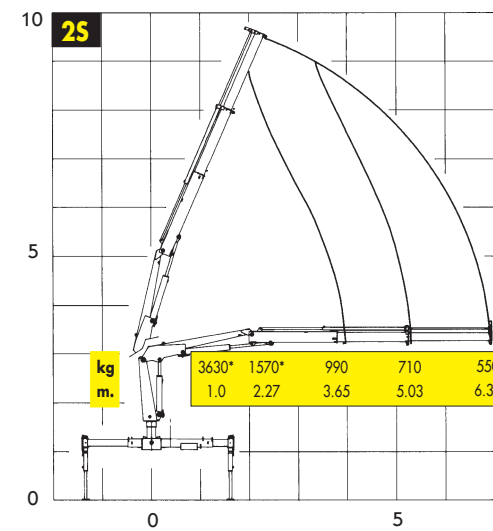
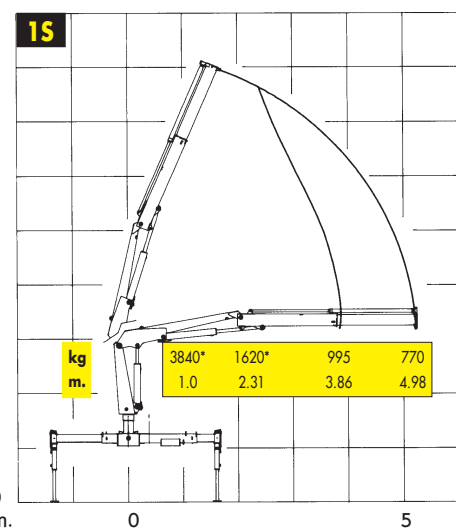



B3
NORMA DIN 15018

CE

COMPANY WITH QUALITY SYSTEM CERTIFIED BY DNV
ISO 9001/2000

AMCO VEBA GROUP

(*) Portata teorica Theoretical lifting capacity